

# SIMAS BUSINESS PARK

34 Simas Street, Salinas, Monterey County

**FOR  
LEASE**

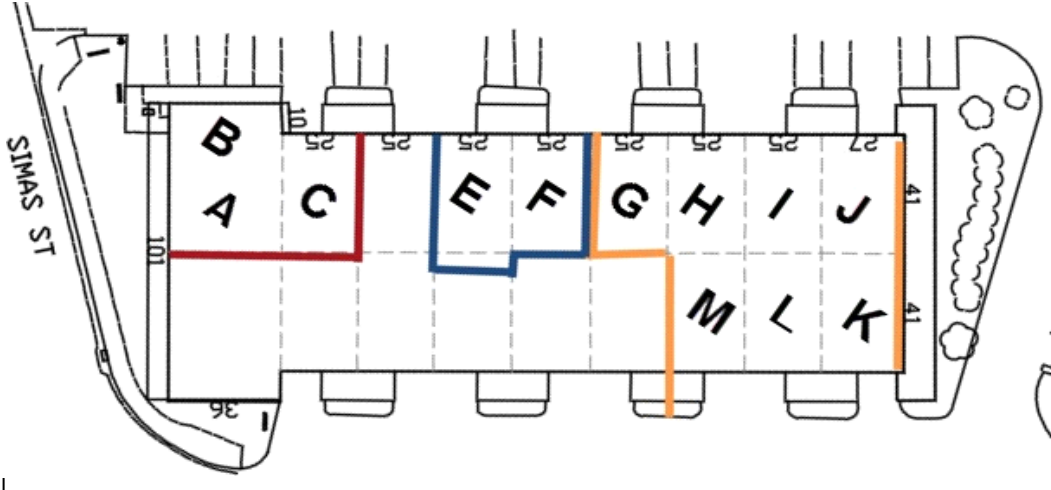

JNM Company  
Commercial Real Estate

John McCormack  
877 687-0459  
CA Lic: 00911993

[johnmccormackjr@montereybay.com](mailto:johnmccormackjr@montereybay.com)  
[www.jnmcommercial.com](http://www.jnmcommercial.com)

The above information has been obtained from sources we deem reliable, but make no representations or warranties, expressed or implied, as to the accuracy of the information. References to square footage or age are approximate. We make no representations or warranties that the premises are free of environmental hazards or suitable in all respects to your contemplated use.

# SIMAS BUSINESS PARK

34 Simas Street, Salinas, Monterey County

**FOR  
LEASE**

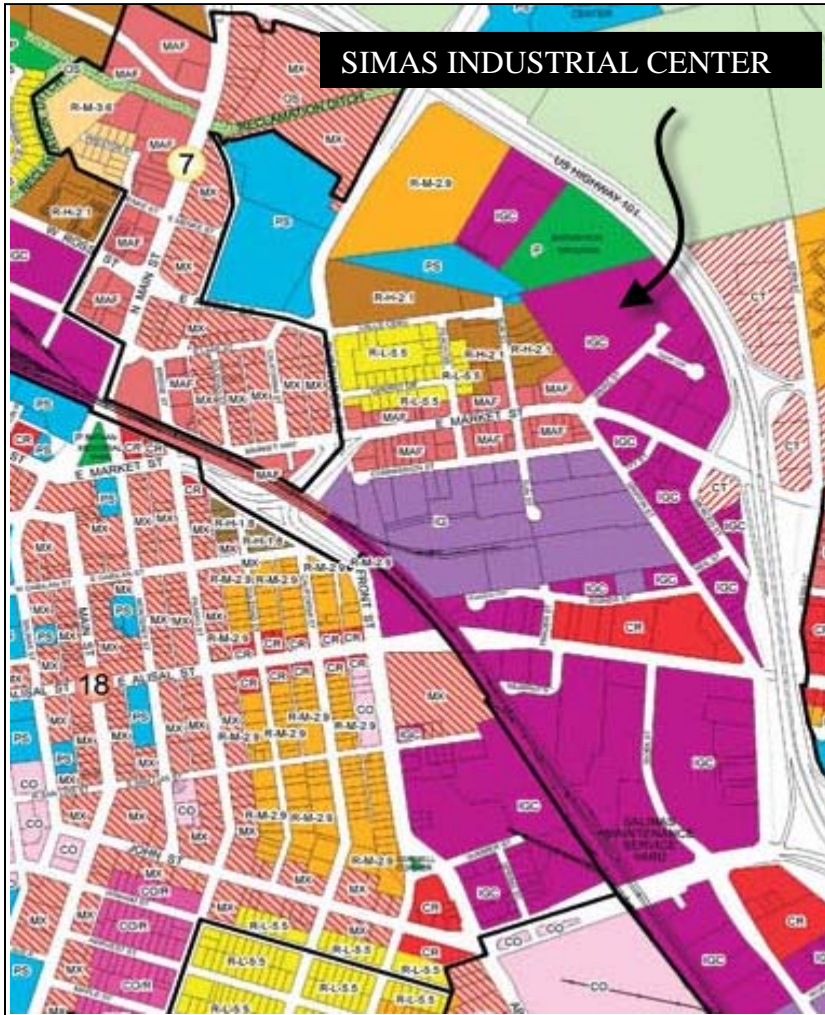

Name: Simas Industrial Center  
Property Address: 34 Simas Street, Salinas  
Zoning: Industrial General Commercial (I-GC)

Building: 19,280SF  
Available: AB&C 2,100SF \$0.70/SF/MO  
E&F 2,450SF \$0.70/SF/MO  
GHIJKL&M 7,700SF \$0.65/SF/MO

Lease Type: Modified Gross  
Ceiling Heights: 14' to 18'  
Roll-up Doors: Yes  
Fire Sprinklers: Yes  
Sky lights: Yes  
Roll-Up Doors: Yes (10 of 12' by 12')  
Parking: Common Parking (414 spaces)  
Highlights: Easy access to Hwy 101, High cube space



JNM Company  
Commercial Real Estate

John McCormack  
877 687-0459  
CA Lic: 00911993

[johnmccormackjr@montereybay.com](mailto:johnmccormackjr@montereybay.com)  
[www.jnmcommercial.com](http://www.jnmcommercial.com)

The above information has been obtained from sources we deem reliable, but make no representations or warranties, expressed or implied, as to the accuracy of the information. References to square footage or age are approximate. We make no representations or warranties that the premises are free of environmental hazards or suitable in all respects to your contemplated use.

# SIMAS BUSINESS PARK

34 Simas Street, Salinas, Monterey County

**FOR  
LEASE**

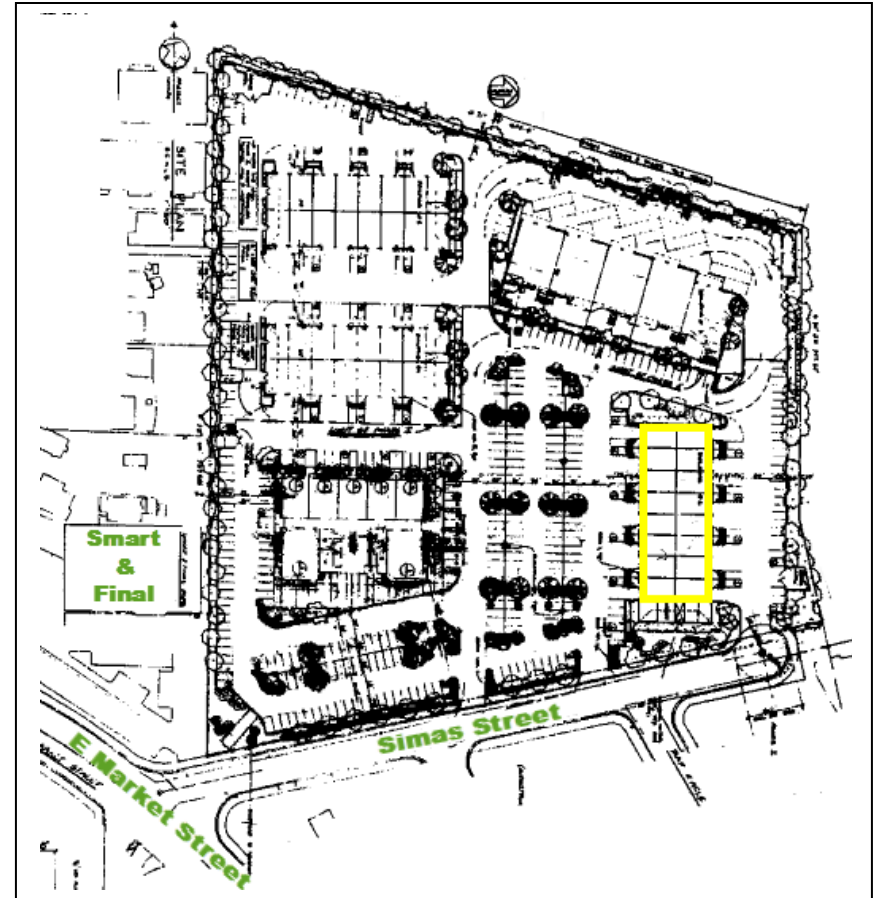

JNM Company  
Commercial Real Estate

John McCormack  
877 687-0459  
CA Lic: 00911993

[johnmccormackjr@montereybay.com](mailto:johnmccormackjr@montereybay.com)  
[www.jnmcommercial.com](http://www.jnmcommercial.com)

The above information has been obtained from sources we deem reliable, but make no representations or warranties, expressed or implied, as to the accuracy of the information. References to square footage or age are approximate. We make no representations or warranties that the premises are free of environmental hazards or suitable in all respects to your contemplated use.

# SIMAS BUSINESS PARK

34 Simas Street, Salinas, Monterey County

**FOR  
LEASE**



## **DISCLAIMER and DISCLOSURE**

This brochure has been prepared to provide summary information to prospective buyers and to establish a preliminary level of interest in the property. Prospective purchasers should perform their own investigations and research. The Listing Broker makes no warranty or representation with respect to the financial condition or business prospects of any tenant, or any tenant's plans or intentions to continue to occupy the subject property. The information contained in this brochure has been obtained from sources we believe to be reliable, however, Listing Broker has not conducted any investigation regarding these matters and makes no warranty or representation whatsoever regarding the accuracy or completeness of the information provided.

Any oral or written representations by Seller or Broker regarding age of improvements, size and square footage of parcel or building(s), or location of property lines may not be accurate. Apparent boundary line indicators such as fences, hedges, walls or other barriers may not represent the true boundary lines, only a surveyor can determine the actual boundary lines. Buyer should consider investigating the property independently.

JNM Company  
Commercial Real Estate

John McCormack  
877 687-0459  
CA Lic: 00911993

[johnmccormackjr@montereybay.com](mailto:johnmccormackjr@montereybay.com)  
[www.jnmcommercial.com](http://www.jnmcommercial.com)

The above information has been obtained from sources we deem reliable, but make no representations or warranties, expressed or implied, as to the accuracy of the information. References to square footage or age are approximate. We make no representations or warranties that the premises are free of environmental hazards or suitable in all respects to your contemplated use.